

Features

- 2 x 5.5 ohm high power, high voltage, thick film protection resistors
- 2 replaceable 2AG fuses in surface-mounted fuse clips

Applications

- Protection circuit for the MH89625C OPS SLIC
- Protection circuit for analog line interfaces, power supplies, etc.

Description

The MH80625C hybrid SIP provides a protection circuit consisting of two 2AG size fuses in surface-mounted fuse clips and two high voltage, high power resistors.

The SIL hybrid, together with an external solid state protector, provides full secondary protection for the MH89625C Off-Premise SLIC, allowing conformance to the requirements of CCITT K.20.

ISSUE 2

April 1995

Ordering Information

MH80625C 10 Pin SIL Package

0°C to 70°C

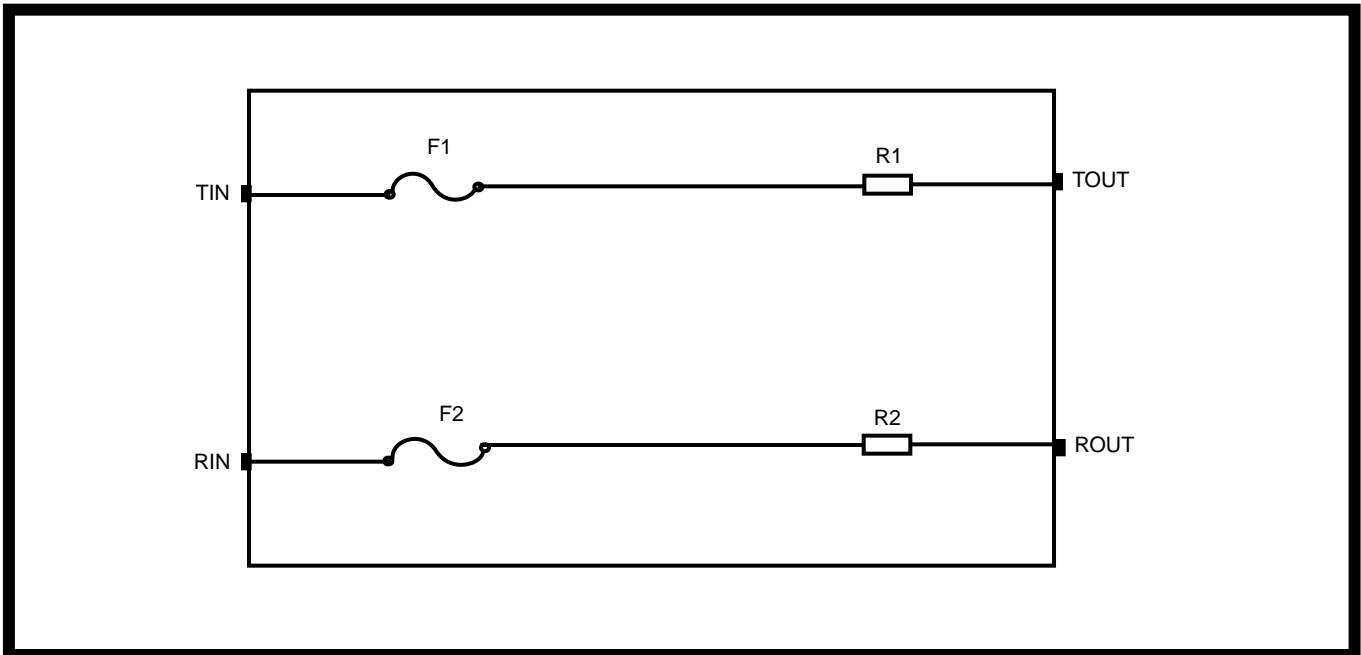

Figure 1 - Functional Block Diagram

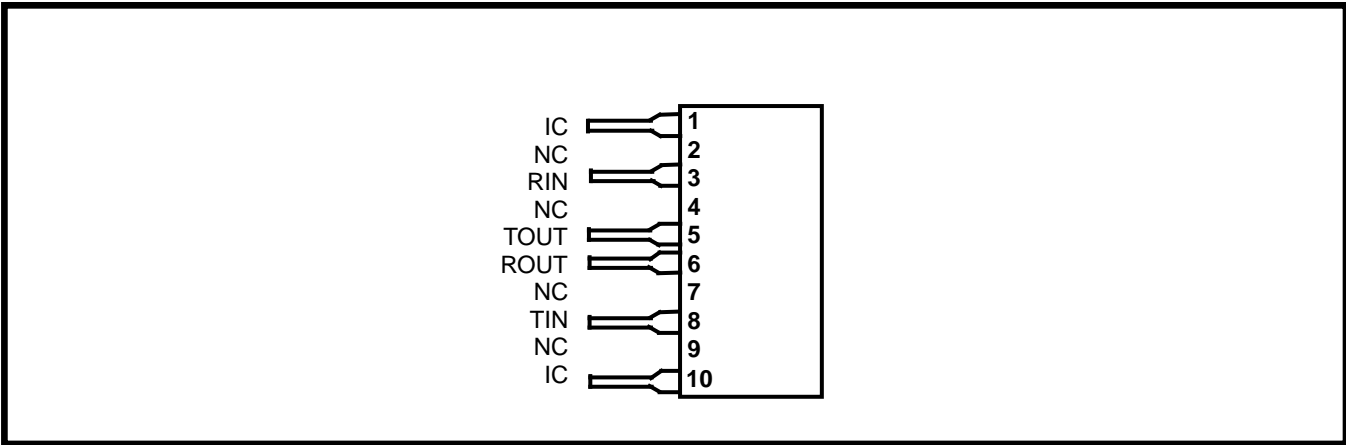

Figure 2 - Pin Connections

Pin Description

Pin #	Name	Description
1	IC	Internal Connection.
2	NC	No Connection.
3	RIN	Ring Input: Connects to Ring conductor of the Subscriber Loop.
4	NC	No Connection.
5	TOUT	Tip Output: Connects to Tip conductor of the SLIC.
6	ROUT	Ring Output: Connects to Ring conductor of the SLIC.
7	NC	No Connection.
8	TIN	Tip Input: Connects to Tip conductor of the Subscriber Loop.
9	NC	No Connection.
10	IC	Internal Connection.

Electrical Characteristics 0°C to 70 ° C

	Characteristics	Symbol	Min	Typ*	Max	Units	Test Conditions
1	Resistance - absolute	R1	4.5	5.5	6	Ω	
2	Resistance - absolute	R2	4.5	5.5	6	Ω	
3	Resistance - match				1	%	Match between R1 & R2
4	Fuse	F1		0.25		Amps	Littlefuse 2AG, 250VAC P/N 229.250 Slow Blow
5	Fuse	F2		0.25		Amps	Littlefuse 2AG, 250VAC P/N 229.250 Slow Blow

* Typical figures are at 25°C and are for design aid only.

	Reference Specification	Test	Description	Performance	Comments
1	CCITT K.20	Lightning Surge Simulation	1kV 10 x 700 μsec	No damage No arcing, fuse intact	See Note 1
2	CCITT K.20	Power Induction	300 Vrms 200 msec	No damage No arcing, fuse intact	See Note 1
3	CCITT K.20	Power Cross	220 Vrms 15 min	No damage No arcing, fuse blows	See Note 1

Note 1: Refer to CCITT K.20 specification for details of tests.

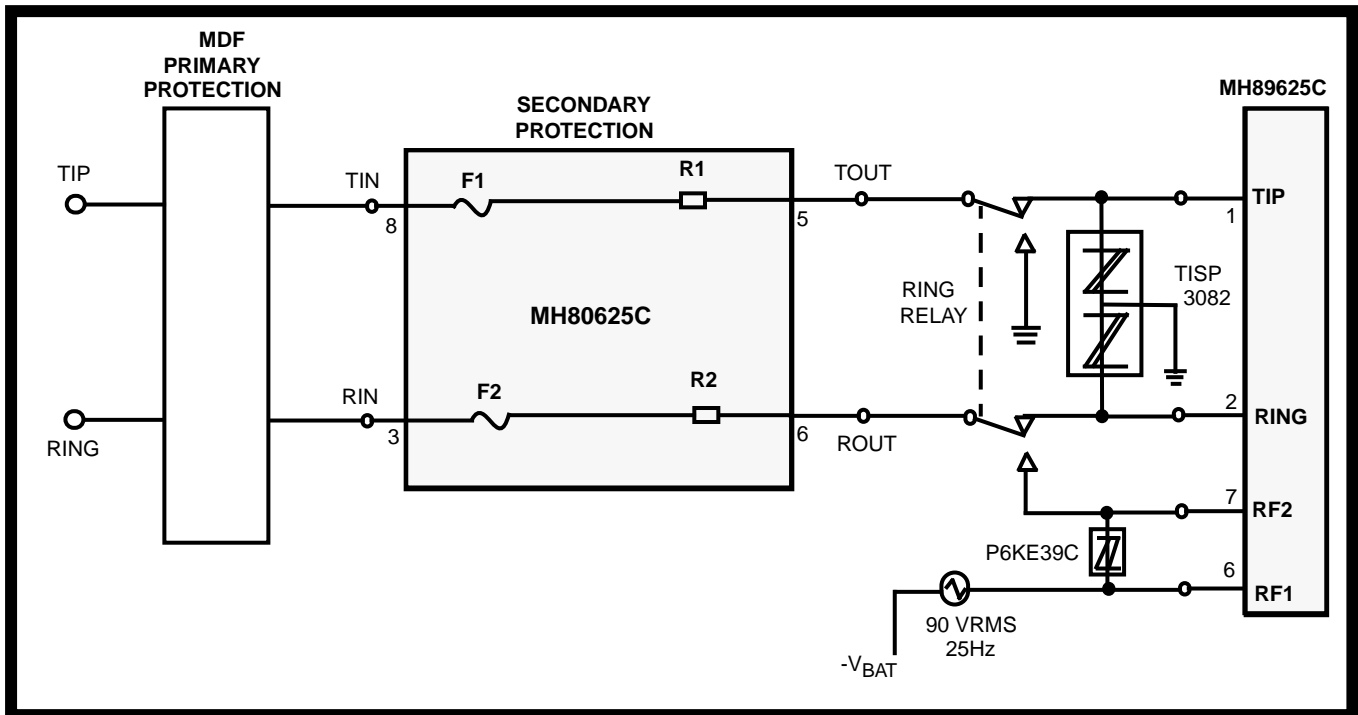

Figure 3 - Application Circuit - Secondary Protection

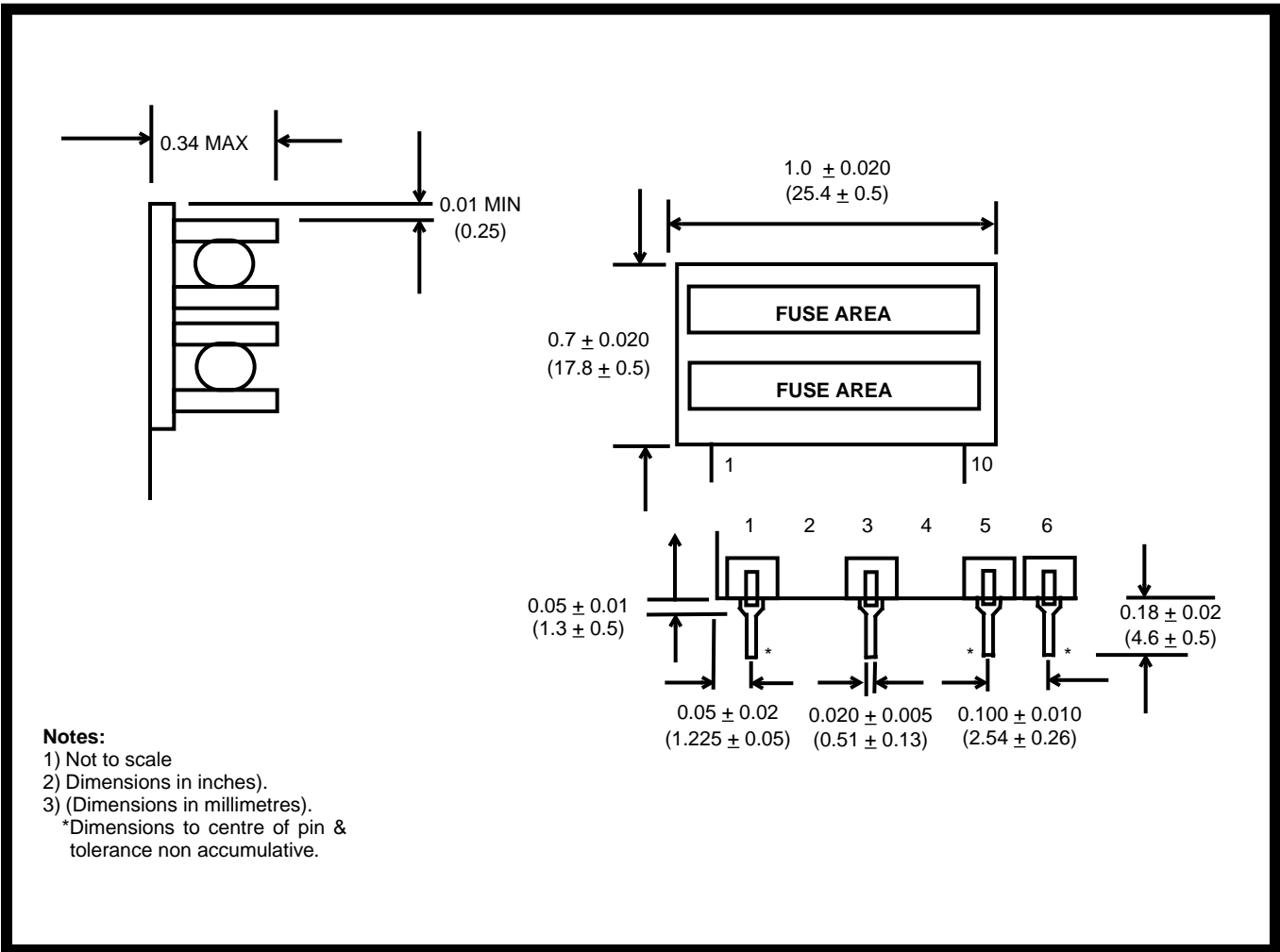

Figure 4 - Mechanical Data